

Design And Finite Element Analysis Of High Speed Compressor Gearbox Unit

Nihad Hasan Talib

M. Tech Mechanical

University College of Engineering and Technology
Acharya Nagarjuna University
Guntur – Andhra Pradesh- 2015

Prof. Gopi Krishna

Prof. In The Dept .Of Mechanical Eng.

University College Of Engineering And Technology
Acharya Nagarjuna University
Guntur – Andhra Pradesh- 2015

Abstract— The project is concerned with the design and analysis of some of the key elements of a gearbox that is used to drive compressor units. Since the pinions rotate at high speeds the complete gear system is subjected to noise and vibrations. The gear system is composed of one bull gear and two pinions. The helical gears are designed as per AGMA standard procedure. Conventional parallel axes helical gears with Involute profile teeth are insensitive to center distance assembly errors and possess line contact under design assembly condition. However, helical gears are very sensitive to axial misalignments, causing discontinuous transmission errors and edge contacts, resulting in noise and vibrations. Therefore the helical gear are modified to attain a localized point contact and to avoid edge contact. The modified helical gear set contains conventional Involute profile, with profile crowning as well as longitudinal crowning. The geometrical models of helical gear are drawn in CATIA V5, Since, the gear system rotates at high speed; this may cause high imbalance forces and vibrations due to the shaft assembly. So, the shafts are designed as integrated shafts for two pinions and a shrink fit assembly for bull gear and shaft, The non-linear finite element contact analysis of helical gear tooth is done using finite element software, ANSYS .workbench 14.5.7. For economy, different models of gear are checked and finally single tooth contact analysis is done for different positions of gear contact.

Keywords— Helical Gear design AGMA, Modeling CATIA – V5 Finite Element Analysis ANSYS

I. INTRODUCTION

Gears are toothed wheels or multi-lobed cams, which transmit power and motion from one shaft to another by means of successive engagement of teeth. Gear drive is a positive drive and maintains constant velocity ratio. It can transfer very high power. As the requirements are broad and are of varying difficulties, gearing is a complex and diversified engineering field. Therefore modifications on the design of gear are suggested depending upon the different applications. The purpose of modification is to improve the performance of the gear. Also gear is machine element which, by means of progressive engagement of projections called (teeth) transmits motion and power between two rotating shafts, gear teeth in general have an involute profile which provides a constant pitch line velocity. The action of such mating gear teeth consists of a combination of rolling and sliding motions, thus producing a positive drive.

II. CLASSIFICATION OF GEAR

The gear are classified on the following basic (1) relation between axes. (2) Shape of the solid on which teeth are cut. (3) Curvature of the tooth profile generally, the following type of gears are most commonly used in industry for power transmission purposes

Spur Gear : A gear having straight teeth along the axis is called the spur gear, spur gear are used to transmit power between two parallel shafts as shown in figure (1-a) A rack is a straight tooth gear which can be thought of as a segment of spur gear of infinite diameter

Helical Gear: they are also used to transmit power between two parallel shafts and teeth are cut on the cylindrical disc. The tooth faces of these gears have a certain degree of helix angle. Angle of opposite hand on pinion and gear as shown in figure (1-b). These gear are smooth in operation and therefore can transmit at a high pitch line velocity.

Bevel gear: when power is to be transmitted between two intersecting shafts, bevel gear are used. The angle of intersection of shafts is called (the shaft angle). The gear blank is a frustum of cone on which teeth are generated. The teeth are straight but their sides are tapered so that all lines, when extended, meet at a common point called the (apex of the cone) as shown figure (1-c).

Worm And Worm gears: in this system of gearing, the axis of the power transmitting shafts are neither parallel nor intersecting but the planes containing the axes are generally at right angles to each other. The teeth used are helical. The schematic diagram of a worm gear set is shown in the figure (1-d).

In a gear drive, the smaller of the two gears in mesh is called (pinion) and the larger gear is customarily designated as (gear). In most of the applications, the pinion is the driving element whereas the gear is the driven element. [18]:

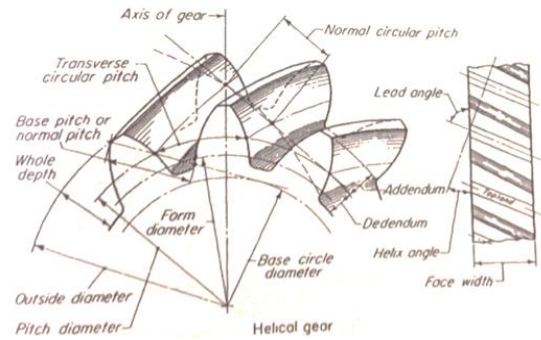
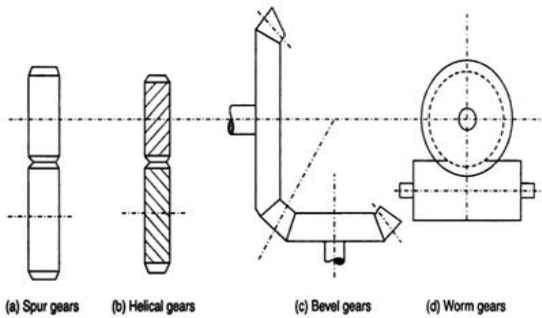

Helical gears normally used for high speed, high power mechanical systems therefore the helical gear used to (1) high speed (2) less noise and vibration (3) used to transmit high power (4)high efficiency 98.....99.5 why??(in a helical gear drive , the contact begins at the tooth end and as the rotation progresses , the contact point moves along whole tooth width till it reaches the other end . this resultin a gradual, even tooth action and load distribution . unlike spur gear drive , the contact line runs diagonal from one end to the other end of the helical tooth . besides , in a helical gear drive , more than one pair of teeth are always in mesh . this , and others characteristics , like shorter lever arm, allow the helical drive to have considerably more load carrying capacity.) [4].

V. DESIGNING OF GEAR

After the text edit has been completed, the paper is ready for the template. Duplicate the template file by using the Save As command, and use the naming convention prescribed by your conference for the name of your paper. In this newly created file, highlight all of the contents and import your prepared text file. You are now ready to style your paper; use the scroll down window on the left of the MS Word Formatting toolbar.

III. USING THE TEMPLATE

In helical gears, the contact between meshing teeth begins with a point on the leading edge of the tooth and gradually extends along the diagonal line across the tooth. There is a gradual pick up of load by the tooth, resulting in smooth engagement and quiet operation even at high speeds. Compared to spur gears of the same size, helical gears can transmit more power and are less noisy. In views of this, helical gears are more efficient and are usually desired for high power transmission. High pitch line velocity . These gears are used in high speed applications .helical gears are of two types-parallel gears(single and double) used for parallel shafts and cross- helical gears used for non- parallel shafts[3].

There are different standards for design of gears, such as German DIN standard, Japanese JS standard and ISO standard. But, the AGMA (American Gear Manufacturer Association) standard is followed for most of the gear design. In this design, the helical gears are designed according to the AGMA standards. On the basic tooth proportions, the AGMA sponsors a large number of standards dealing with gears design, specification materials, ratings and inspection. The most important AGMA standards are

“Gear Handbook” 390.03, “Gear Classification and Inspection Handbook” 2000-A88

The LEWIS Bending Equation

In design of gears, It is required to decide the weaker between pinion and gear. When the same material is used for pinion and gear, the pinion is always weaker than gear [6].

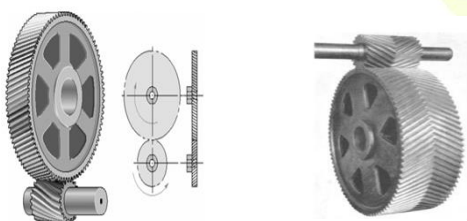

Fig. 2

IV. NOMENCLATURE OF THE HELICAL GEAR

Helical gears are also called as prompt gears, prompt gears are used to transmit rotary motion between parallel shafts [8]. These are usually cylindrical in shape and its teeth are have certain degree of helix angle. In a couple of gears, the major one is often called the GEAR and, the minor one is called the PINION.

$$Y = 0.154 - \frac{0.912}{Z_E}$$

According to AGMA standard procedure Beam Strength,

$$S_t = \frac{F_t \times K_a}{K_v} \times \frac{1}{b \times m_n} \times \frac{K_s \times K_m \times K_b}{J}$$

$$S_t = \frac{F_t \times K_a}{K_v} \times \frac{1}{b \times m_n} \times \frac{K_s \times K_m \times K_b}{J}$$

$$\left[380 \geq \frac{2833.4 \times 1.75}{0.646} \times \frac{1}{55 \times m_n} \times \frac{1 \times 1.2}{0.154 - 7.52 \times 10^{-3} \times m_n} \times \frac{1 \times 1}{1} \right]$$

$m_n=3.439\text{mm}$

STRESS CALCULATIONS OF GEARS

A-Bending stresses

$$S_t = \frac{(F_t \times K_a \times K_s \times K_m)}{(K_v \times b \times m_n \times J)}$$

= 93.55MPa

B. Contact Stress

$$S_c = C_p \times \sqrt{\frac{W_t \times C_a \times C_s \times 0.93 \times C_m \times C_f}{C_v \times d \times b \times I}}$$

$S_c = 459.128 \text{ MPa}$

C. Static tooth load

$$F_s = \sigma_e \times b \times \pi \times m_n \times Y$$

D. Wear tooth load

$$F_w = \frac{D_1 \times b \times Q \times K}{\cos^3 \psi}$$

E. Dynamic effect

$$F_D = F_t + \frac{21V_1 \times (b \times C \times \cos^2 \psi + F_t) \times \cos \psi}{21V_1 + \sqrt{b \times C \times \cos^2 \psi + F_t}}$$

VI. MODELING

Gears modeling is very useful and important, as to make real gear transmission simulation. CATIA stand for Computer Aided Three Dimensional Interactive Application. It is a product modeling software can be custom-made via Application Programming Interfaces (API). CATIA V5 features are parametric solid/surface-based wrap up which uses NURBS as the interior surface representation and has quite a lot of workbenches that make available KBE support The most widely used software in modeling now a days is CATIA.

It can be appreciable to be considered as an User friendly software and capable of presenting the existence on any platform which is related to computer part of programming the commands There by accuracy of the software for drafting is almost reaches to preferable real time values. Though there are so many versions in CATIA the V5 version has been used for present work . For helical gear in CATIA, relation and equation modeling is used. Relation is used to express dependencies among the dimension needed for defining the basic parameters on which the model is depends

In this work, module, pressure angle, numbers of teeth of bull gear is taken as input parameters. CATIA V5 uses these parameters,

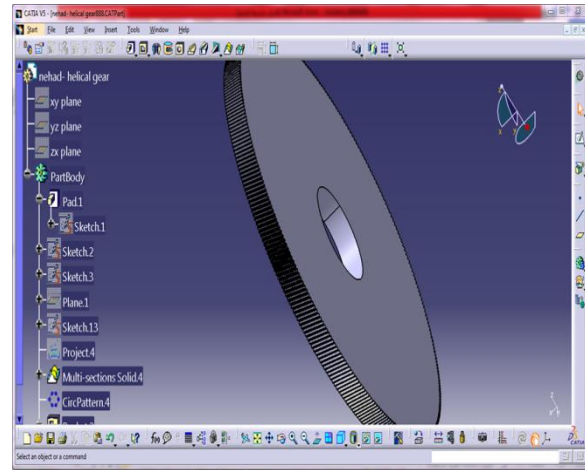

Fig. 4. Bull Gear

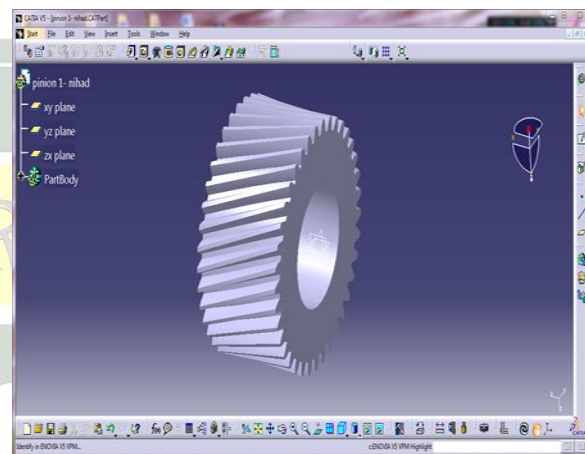

Fig. 4. Pinion 1

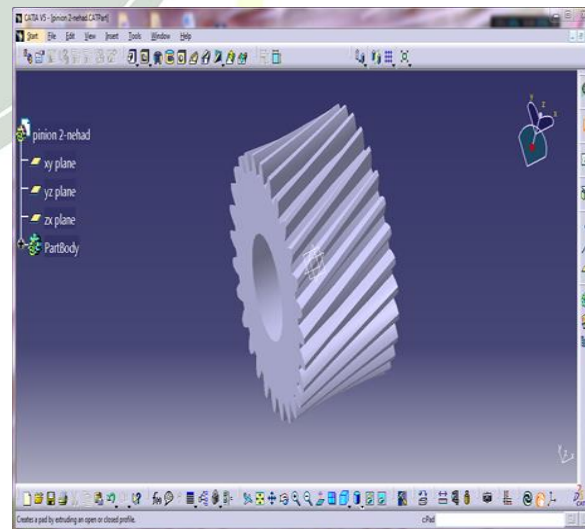

Fig. 6. Pinion 2

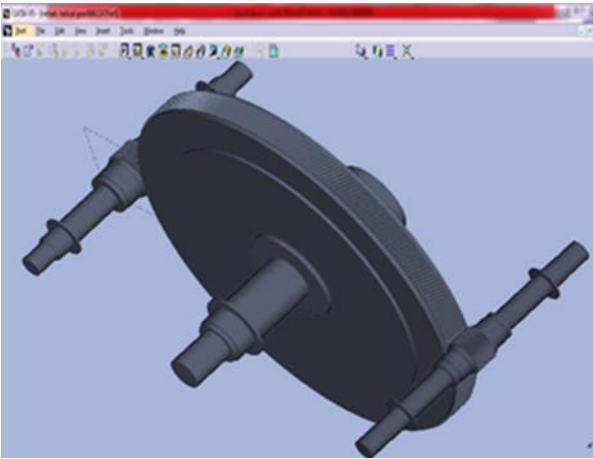

Fig. 7. Assembly high speed gear

A. Contact Stresses

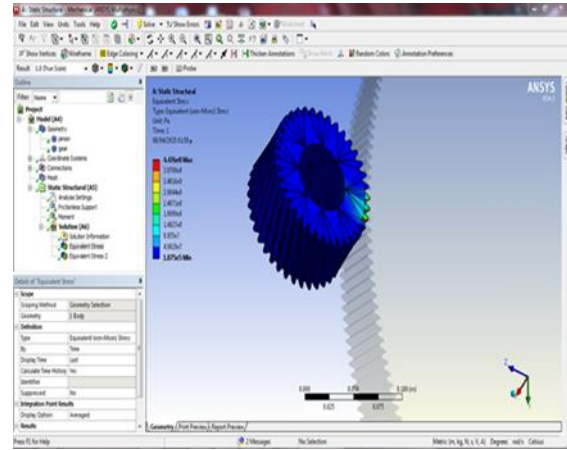

Fig. 9. Stresses contact in pinion 2

VII. FINITE ELEMENT STRESS ANALYSIS RESULTS

Three different models were tested with single tooth. Model 1 contains full pinion and full gear with one tooth. Model 2 contains full pinion and large part of gear with one tooth. Model 3 contains one tooth of pinion and gear. A small portion of rim is also included into the volume of pinion and gear. Three models of a helical gear drive are shown in the figures. The volume of pinion is divided into three sub-volumes using auxiliary intermediate surfaces. The volume of gear is divided into six sub-volumes using auxiliary intermediate surfaces. Each volume of pinion and gear is discretized by finite elements. The numbers of elements at the possible point of contact and at the root fillet are higher than the other regions. A torque, $T = 153.9 \text{ N}\cdot\text{m}$ is applied to the rotational axis of pinion.

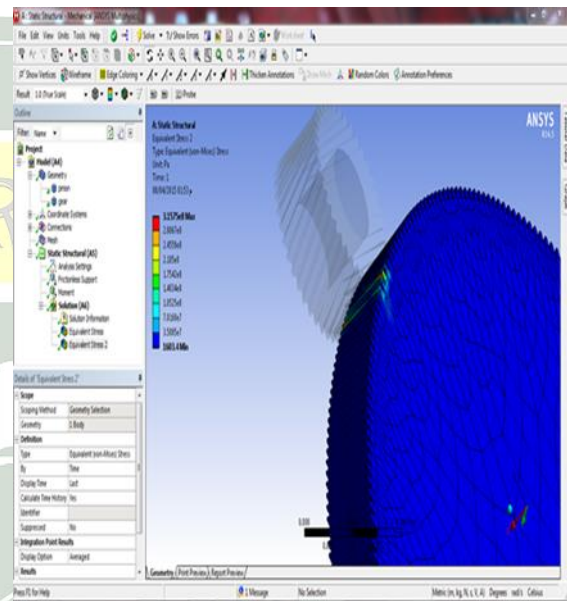

Fig. 10. Stresses contact in gear

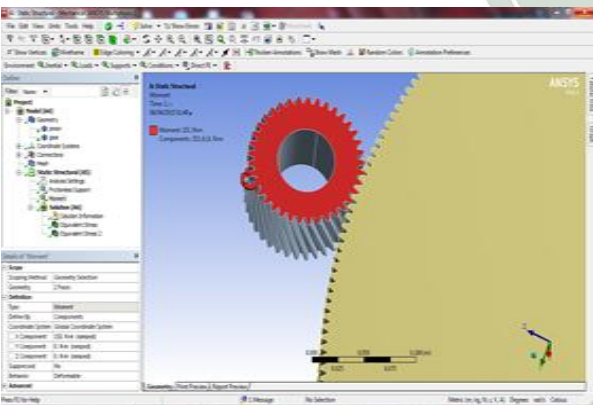

Fig. 8. Applied torque

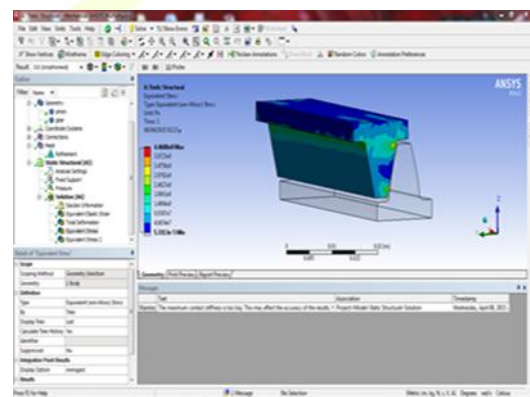

Fig. 11. Stresses contact in tooth pinion

Models	Number of elements	Number of nodes	Contact Stress in Pinion(Mpa)	Contact Stress in Gear (Mpa)
Model 1	33,400	37,507	447.601	315.750
Model 2	11,600	13,945	449.553	318.218
Model 3	5,480	6,981	446.881	330.775

From above results, it is visible that there is no variation in the contact stress and hence, it is economical to use one tooth of pinion and gear for contact analysis.

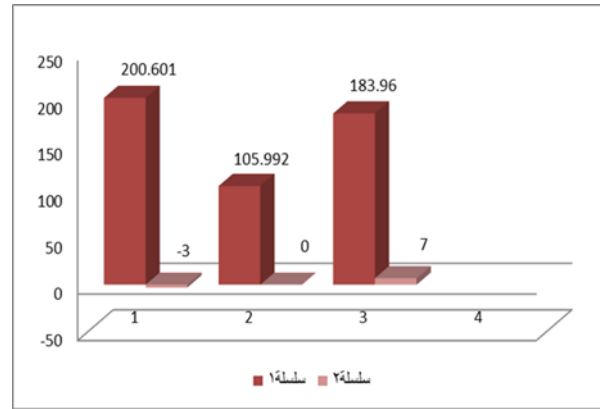
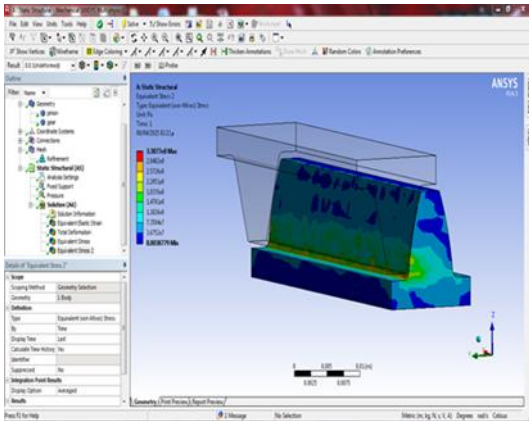

Fig. 12. Stresses contact in tooth gear

No	Contact stress in AGMA	Contact stress in ANSYS	Differences
1	459.128	446.88	2.086 %

No	Bending stress in AGMA	bending stress in ANSYS	Differences
1	93.553	105.992	10.7%

To study the contact stress at different location of tooth flank, the pinion is rotated by some angle to get position of contact with gear. The different positions of the point of contact are -3° , 0° , 3° , and 7° . The edge contact in (7° and -3°) can take place twice during the engagement of a pair of teeth. The first time the tip of the pinion tooth impacts the root of the gear tooth. Then the edge contact takes place at the end of two teeth.

C. Center Distance Variation

The center distance variations may have occurred in the process of the assembly. The dislocation bearing contact will result in increase of the bending stress and contact stress.

The contact stress after the center distance variation of 1mm in pinion is 463.011MPa

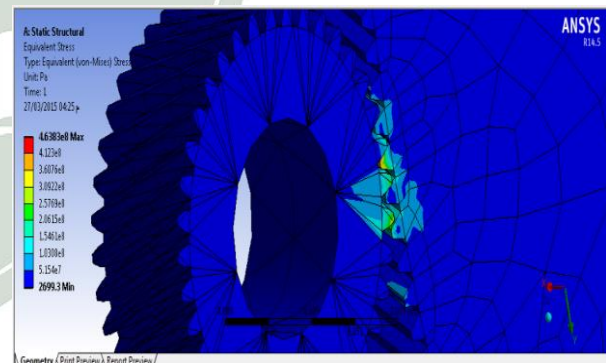
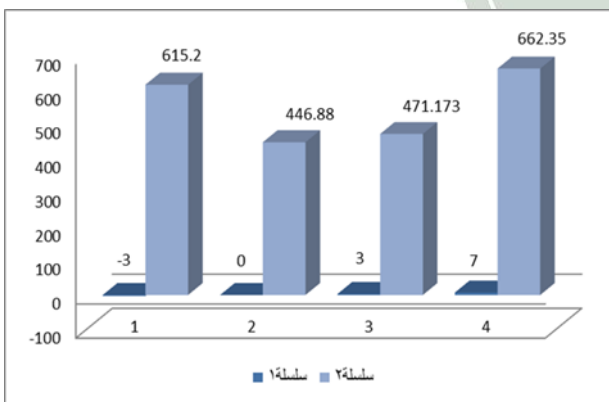

B. Bending Stresses

Generally, the bending stresses in the fillet of the two contacting tooth side are considered tensile stresses and those in the fillets of the opposite, unloaded tooth side, are considered compressive stresses. The fillet stresses are determined at three pinion's rotational angles 0° , 7° and -3°

CONCLUSION

In this study, finite element stress was performed to investigate the contact stresses and the bending stresses of a helical gear set as mentioned above. The geometrical model of a helical gear was generated using parametric equation of involute curve. Commercial FEA software, ANSYS workbench 14.5.7

1. The contact stresses of a helical gear calculated AGMA standard is close to the contact stress obtained from ANSYS, and contact stresses are below the allowable contact stresses there for the gear is safe in contact stresses.

2-The bending stresses are below the allowable bending stresses. Hence the gear is safe in bending the bending stresses of an helical gear calculated AGMA standard is close to the bending stress obtained

3-The effect of center distance variation and axial misalignment were studied. The center distance variation creates dislocation of bearing contact which results in increase of bending stress and contact stress the axial misalignment will create dislocation of bearing contact

4-Shafts are designed, in ch-8 by taking all axial, radial and tangential forces including the weight of the gear into consideration. A factor of safety of 2 taken for calculations. The deflection value of the shaft are under the limit so, design is safe under high speed rotation.

REFERENCES

- [1] Peter lynwander (Gear Design system , design and application, peter American lohmann corporation hillside New Jersey,2002
- [2] Joseph E.Shigley and Charles R. Mischke (Mechanical Engineering Design)six edition, joseph professor Emeritus the university of Michigan 2006
- [3] Darle W.Dudley (Hand book of practical gear design)Darle Consultant Dudley technical Group,INC2008
- [4] Gitin M. Maitra (Hand Book Of Gear Design)second edition , Gitin formerly manager design department Rourkela steel plant 1998
- [5] V.B. Bhandari (Design Of Mchine Elements)Third Edition 2010
- [6] Dudleys (Hand Book Of Practical Gear Design And Manufacture)second edition by(Stephen P.Radzevich)2011
- [7] Vineet Shibe (Computer Aided Engineering Of Gear Box)and stress analysis using ANSYS 2012
- [8] Dennis P.townsend (Dudleys Gear Hand Book The design, Manufacture ,And Application. Second Edition 2010
- [9] T .Krishna Raw (Design Of Machine Elements)Volume 2, T. Krishna Gandhiji Institute Of Science And Technology1989
- [10] Shigleys (Mechanical Engineering Design) by Richard G. Budynas And J, Keith Nisbett, Ninth Edition 2007
- [11] Vijay Kumar Jadon Suresh Verma (Analysis And Design Of Machine Elements)V.K Formoer Associate Professor, THAPAR UNIVERSITY 2011
- [12] Prof. Sham Tickoo And Avijeet P. Suryavanshi (CATIA V5 - 6R2013)For Engineers And Designer 2013
- [13] Yi -Cheng Chen, Chung-Biau Tasy, "Stress analysis of a helical set with localized bearing contact." Finite Elements in Analysis and Design, 2002.
- [14] Faydor L. Litvin, Alfonso Fuentes, Ignacio Gonzalez-Perez, Luca Carvenali, Kazumasa Kawasaki, Robert F. Handschuh, "Modified involute helical gear:computerized design. simulation of meshing and stress analysis." Computer Methods in Applied Mechanics and Engineering, 2003.
- [15] F. L. Litvin, D. H. Kim, "Computerized design, generation and simulation of meshing of modified involute spur gears with localized bearing contact and reduced level of transmission errors." ASME Journal of Mechanical Design, March, 1997.
- [16] F. L. Litvin, J. S. Chen, J. Lu, "Application of finite element analysis for determination of load share, real contact ratio, precision of motion and stress analysis." ASME Journal of Mechanical Design, December 1996.
- [17] Y. Zhang, Z. Fang, "Analysis of transmission errors under load of helical gears with modified tooth surfaces." ASME Journal of Mechanical Design, March 1997.
- [18] Ch. Rama Mohana Rao, G. Muthuveerappan, "Finite element modeling and stress analysis of helical gear teeth." Computers and Structures, June 1992.

